



# Running Board

Part No. R0007RB



**Fits: 2018-Current Buick Enclave/2018-Current Chevy Traverse/Current Ford Explorer/2005-Current Nissan Frontier Crew Cab/2005-2010 Toyota Sienna**



REMOVE CONTENTS FROM BOX. VERIFY ALL PARTS ARE PRESENT.



READ INSTRUCTIONS CAREFULLY BEFORE STARTING INSTALLATION.

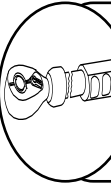

DO NOT OVER TORQUE. STANDARD OPERATING LOAD FOR TIGHTENING BODY MOUNT NUTS & BOLTS VARIES FROM 7 TO 8.5 FOOT POUND FOR M6 ,18 TO 20 FOOT POUND FOR M8 AND 35-40 FOOT POUND FOR M10



60-180 min

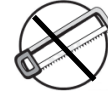

Cutting Not Required



Drilling Not Required



support@trailfx.com



1 866 638 4870



POLISHED STAINLESS STEEL - LIMITED LIFETIME  
POWDER COATED BLACK - 3 YEARS

### PARTS LIST:

Qty	Part Description	Qty	Part Description
1	Driver/Left Viewpoint Running Board	2	10mm J-Bolts
1	Passenger/Right Viewpoint Running Board	2	10mm x 20mm x 2mm Flat Washers
1	Driver/Left Front Mounting Bracket	2	10mm Lock Washers
1	Passenger/Right Front Mounting Bracket	2	10mm Hex Nuts
1	Driver/Left Center Mounting Bracket	10	8mm Plastic Retainers
1	Passenger/Right Center Mounting Bracket	10	8-1.25mm x 30mm Bolt Plates
1	Driver/Left Rear Mounting Bracket	6	8-1.25mm x 30mm Hex Bolts
1	Passenger/Right Rear Mounting Bracket	22	8mm x 24mm x 2mm Flat Washers
1	Driver/Left Front Support Bracket	16	8mm Lock Washers
1	Passenger/Right Front Support Bracket	16	8-1.25mm Hex Nuts
1	Driver/Left Center Support Bracket	12	6-1.0mm x 20mm T-Bolts
1	Passenger/Right Center Support Bracket	12	6mm x 18mm x 1.6mm Flat Washers
1	Driver/Left Rear Support Bracket	12	6mm Lock Washers
1	Passenger/Right Rear Support Bracket	12	6mm Hex Nuts
2	10mm Plastic Retainers	2	2mm Spacers

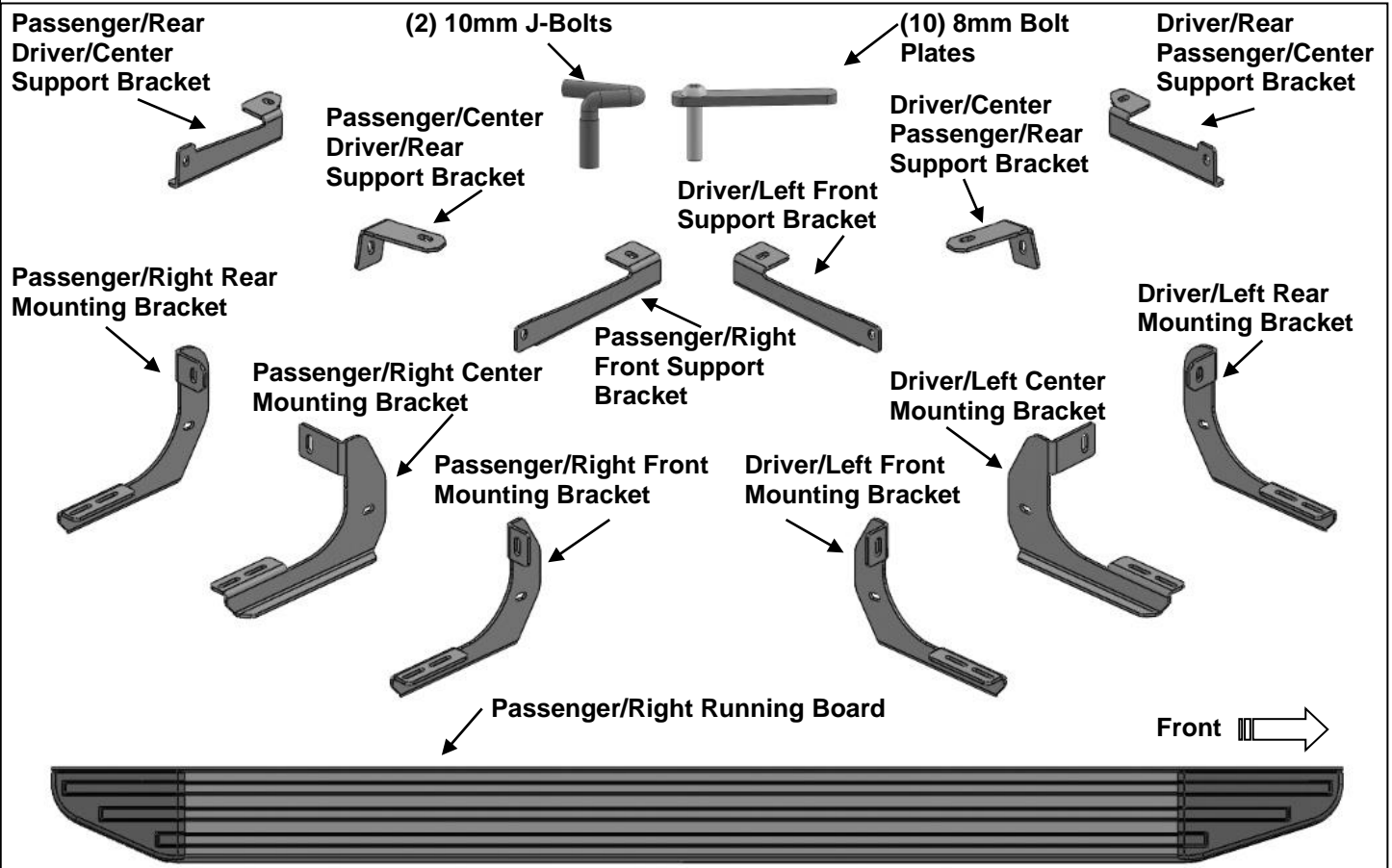
**PROCEDURE:**

1. **REMOVE CONTENTS FROM BOX. VERIFY ALL PARTS ARE PRESENT. READ INSTRUCTIONS CAREFULLY BEFORE STARTING INSTALLATION.**
2. Start installation on the Passenger/Right side of the vehicle. Locate the front mounting location, **(Figure 1)**. Remove the rubber plug from the inner body panel.
3. Select (1) 8mm Bolt Plate. Thread (1) 8mm Plastic Retainer onto the Bolt Plate. **NOTE:** The Plastic Retainer is designed to help hold the Bolt Plate in place and to prevent the Bolt Plate from falling into the body panel. Insert the Bolt Plate into the front mounting location.
4. Select the Passenger/Right Front Mounting Bracket. **Important:** Front and Rear Mounting Brackets are similar, but they are unique. The Front Mounting Bracket has an angled top behind the mounting tab, **(Figure 2)**. Attach the bracket to the Bolt Plate with (1) 8mm Flat Washer, (1) 8mm Lock Washer and (1) 8mm Hex Nut, **(Figures 3 & 4)**. Do not tighten hardware at this time.
5. Select (1) 8mm Bolt Plate. Thread (1) 8mm Plastic Retainer onto the Bolt Plate. Insert the Bolt Plate into the hole in the bottom of the frame, **(Figures 1 & 5)**. Select the Passenger/Right Front Support Bracket. Attach the inner bent end of the Support Bracket to the Bolt Plate with (1) 8mm Flat Washer, (1) 8mm Lock Washer and (1) 8mm Hex Nut, **(Figure 5)**.
6. Attach the flat outer end of the Support Bracket to the front of the Mounting Bracket with (1) 8mm x 30mm Hex Bolt, (2) 8mm Flat Washers, (1) 8mm Lock Washer and (1) 8mm Hex Nut, **(Figures 6 & 7)**. Do not tighten hardware at this time.
7. Move along the body panel to the center mounting location, **(Figures 2 & 9)**. Remove the rubber plug from the inner body panel. Insert (1) 8mm Bolt Plate with Plastic Retainer into the hole in the body panel. Select the Passenger/Right Center Mounting Bracket, **(Figure 9)**. Repeat **Step 3 & 4** to attach the Bracket to the Bolt Plate, **(Figure 9 & 11)**. Do not tighten hardware at this time.
8. Select the Passenger/Right Center Support Bracket. Hold the Bracket up in position to determine correct mounting location. Insert (1) 10mm J-Bolt, if necessary, use a 7/16" drill bit (not included) to open up the small hole in the bottom of the body panel reinforcement, **(Figure 8)**. Select (1) 10mm Plastic Retainer. Thread the Plastic Retainer onto the J-Bolt to hold it in place, **(Figures 10 & 11)**.
9. Attach the Passenger/Right Center Support Bracket to the J-Bolt with (1) 2mm Spacer, (1) 10mm Flat Washer, (1) 10mm Lock Washer and (1) 10mm Hex Nut, **(Figures 10 & 12)**. Attach the Support Bracket to the front of the Center Mounting Bracket with (1) 8mm x 30mm Hex Bolt, (2) 8mm Flat Washers, (1) 8mm Lock Washer and (1) 8mm Hex Nut, **(Figures 10 & 12)**. Do not tighten hardware at this time.

10. Move to the rear mounting location, (**Figures 13 & 15**). Remove the plug from the inner body panel. Select the Passenger/Right Rear Mounting Bracket. Repeat **Steps 3 & 4** to attach the Bracket to the Bolt Plate in the body panel, (**Figure 14**).
11. Select (1) 8mm Bolt Plate. Select the Passenger/Right Rear Support Bracket. Repeat **Steps 5 & 6** to attach the Support Bracket to the Mounting Bracket, (**Figures 15 & 16**). Do not tighten hardware at this time.
12. Select the Passenger/Right Running Board. Insert (6) 6mm T-Bolts into the channels in the bottom of the Running Board, (3) per channel, (**Figure 17**). Place the Running Board on the Brackets. Line up the T-Bolts with the Mounting Brackets. Attach the Running Board to the Brackets with (6) 6mm Flat Washers, (6) 6mm Lock Washers and (6) 6mm Hex Nuts, (**Figures 18 & 19**). Do not tighten hardware at this time.
13. Level and adjust the Running Board and tighten all hardware at this time.
14. Repeat **Steps 2—13** to install the Driver/Left Running Board.
15. Do periodic inspections to the installation to make sure that all hardware is secure and tight.

### Passenger/Right Side Installation Pictured

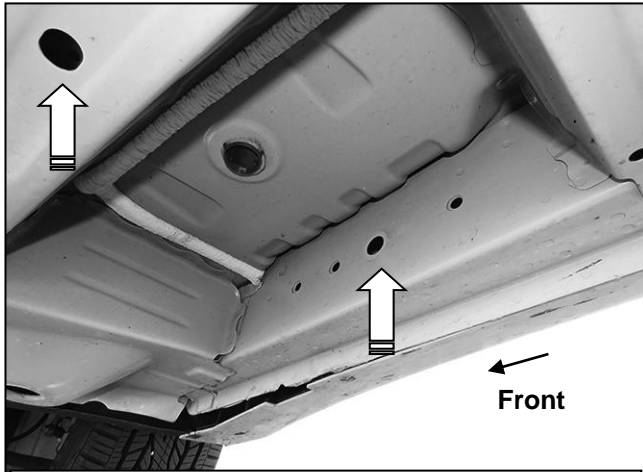

(Fig 1) Passenger/Right front mounting location

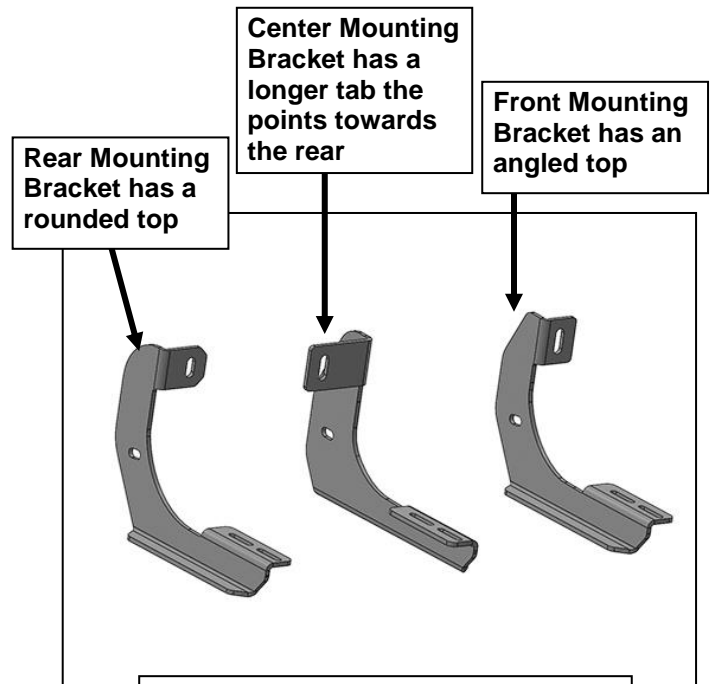

(Fig 2) Mounting Brackets are unique

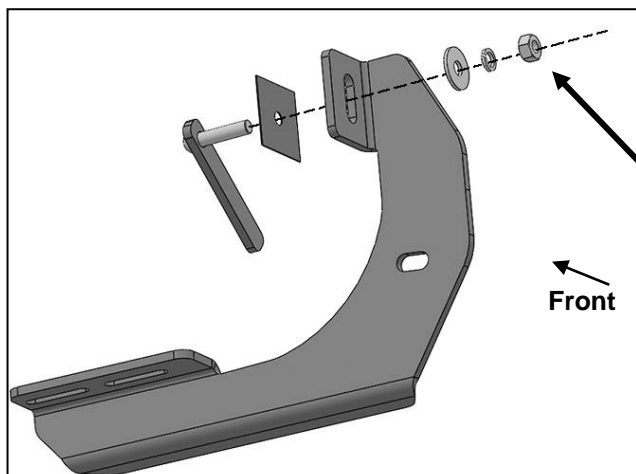

(Fig 3) Attach Passenger/Right Front Mounting Bracket to Bolt Plate in body panel

8mm Bolt Plate  
8mm Plastic Retainer  
8mm Flat Washer  
8mm Lock Washer  
8mm Hex Nut

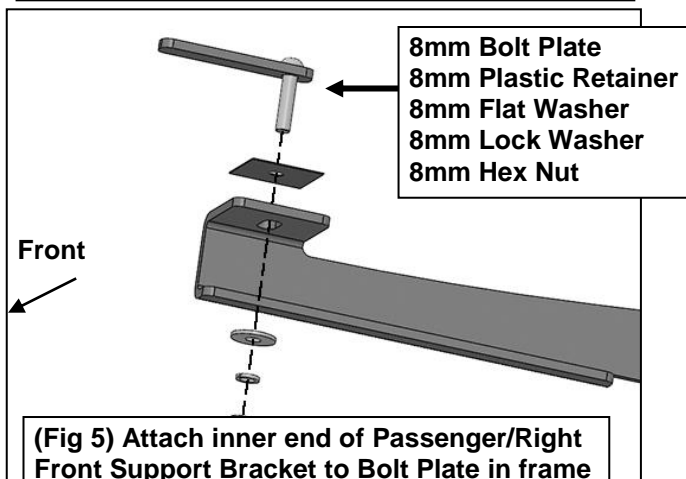

(Fig 5) Attach inner end of Passenger/Right Front Support Bracket to Bolt Plate in frame

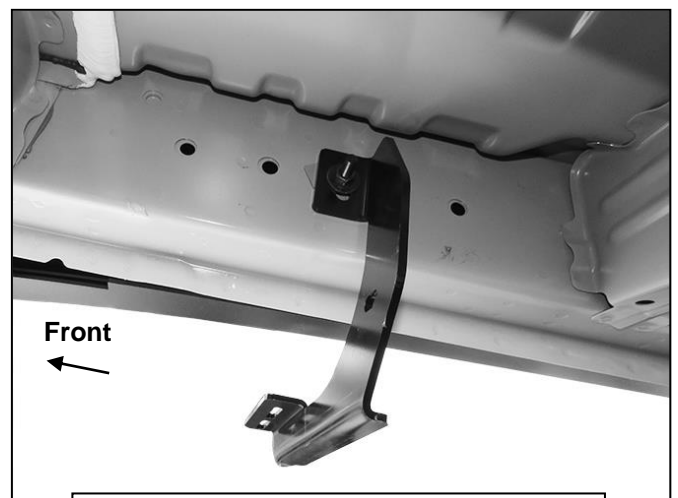

(Fig 4) Passenger/Right Front Mounting Bracket attached to inner body panel

### Passenger/Right Side Installation Pictured

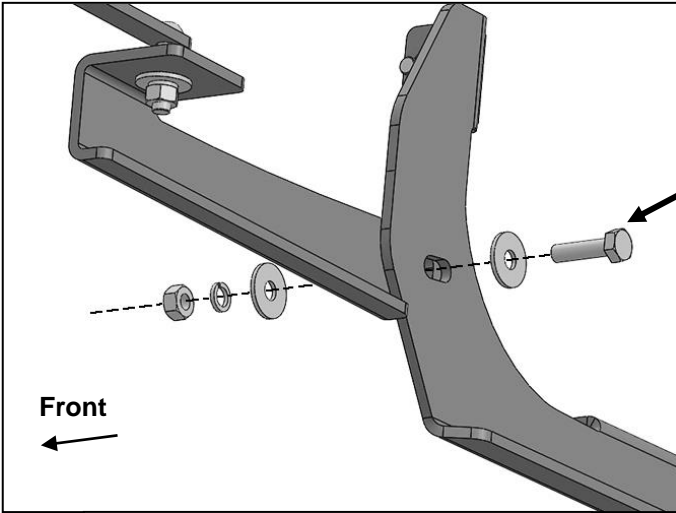

8mm x 30mm Hex Bolt  
(2) 8mm Flat Washers  
8mm Lock Washer  
8mm Hex Nut

(Fig 6) Attach Passenger/Right Front Support Bracket to Mounting Bracket

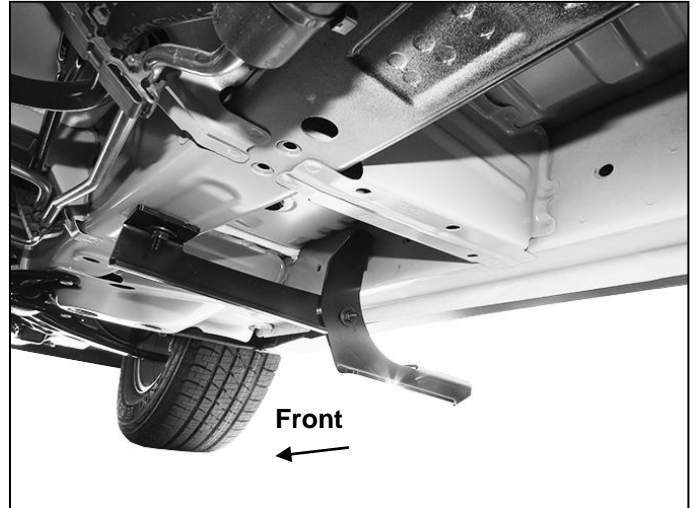

(Fig 7) Passenger/Right Front Brackets attached

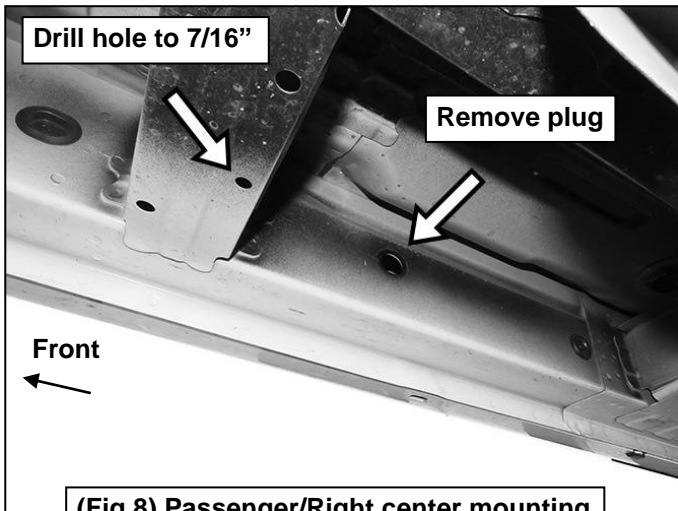

(Fig 8) Passenger/Right center mounting location. If necessary, drill out small hole to 7/16\" to fit J-Bolt

8mm Bolt Plate  
8mm Plastic Retainer  
8mm Flat Washer  
8mm Lock Washer  
8mm Hex Nut

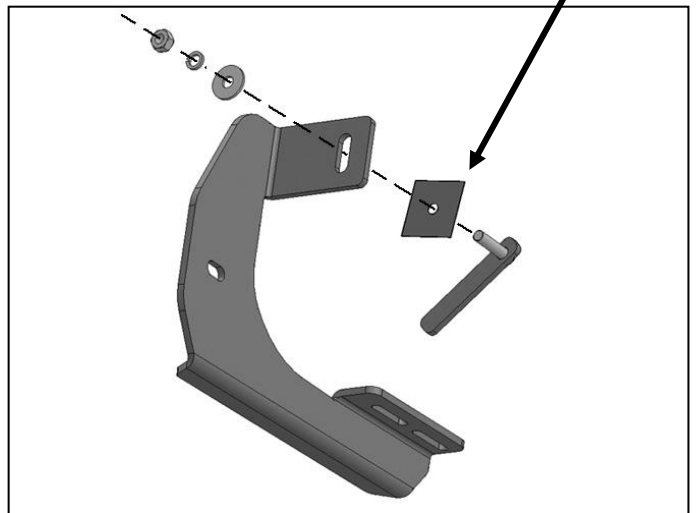

(Fig 9) Attach Passenger/Right Center Mounting Bracket to Bolt Plate in body panel

### Passenger/Right Side Installation Pictured

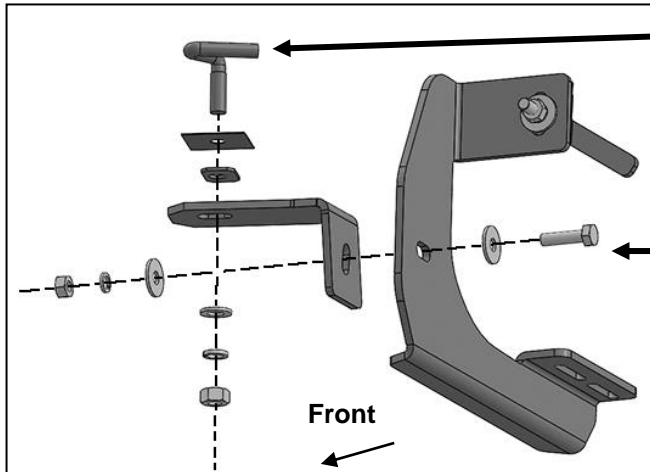

- 10mm J-Bolt
- 10mm Plastic Retainer
- 2mm Spacer
- 10mm Flat Washer
- 10mm Lock Washer
- 10mm Hex Nut

- 8mm x 30mm Hex Bolt
- (2) 8mm Flat Washers
- 8mm Lock Washer
- 8mm Hex Nut

(Fig 10) Attach Passenger/Right Center Support Bracket to Mounting Bracket and J-Bolt

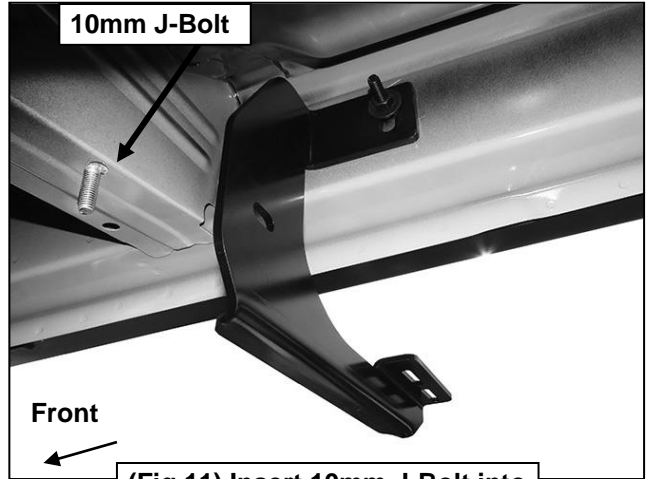

(Fig 11) Insert 10mm J-Bolt into the hole in bottom of support

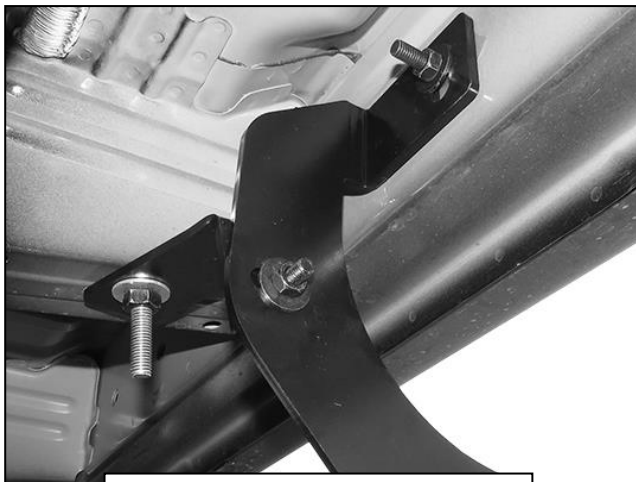

(Fig 12) Passenger/Right Center Support Bracket attached

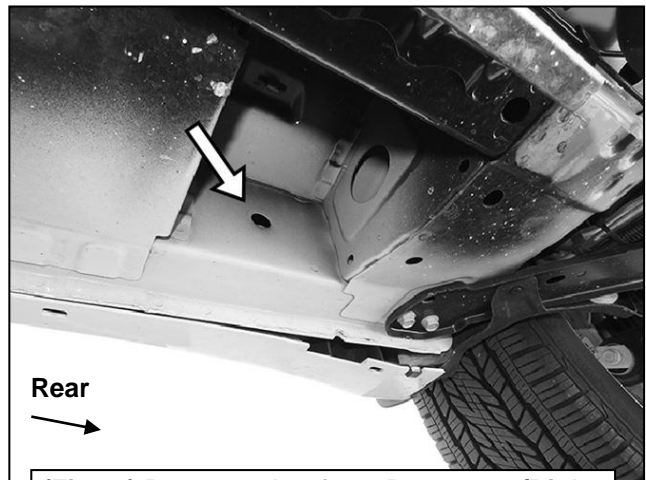

(Fig 13) Remove plug from Passenger/Right rear mounting location

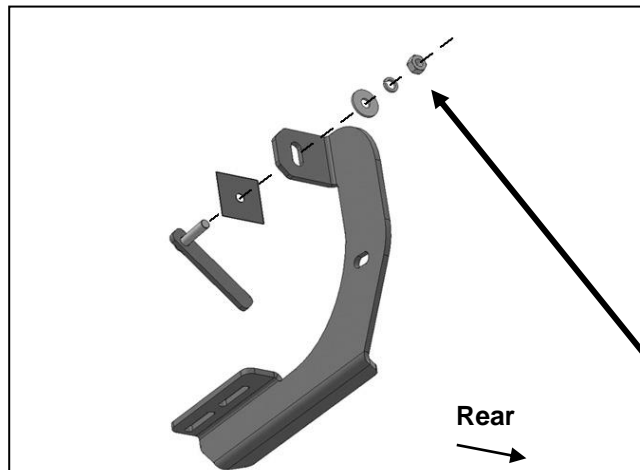

(Fig 14) Attach Passenger/Right Rear Mounting Bracket to Bolt Plate in body panel

- 8mm Bolt Plate
- 8mm Plastic Retainer
- 8mm Flat Washer
- 8mm Lock Washer
- 8mm Hex Nut

### Passenger/Right Side Installation Pictured

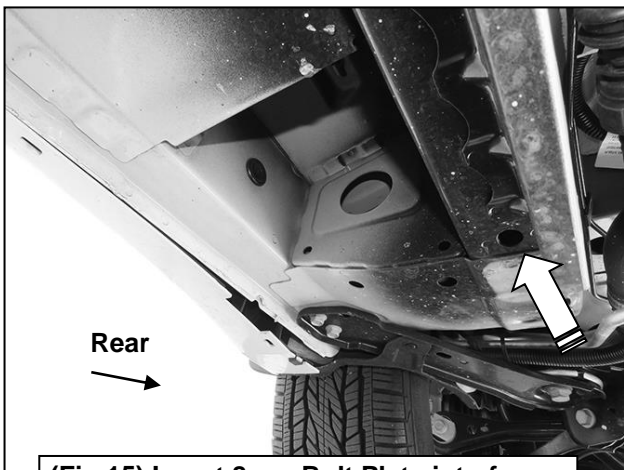

(Fig 15) Insert 8mm Bolt Plate into frame

- 8mm Bolt Plate
- 8mm Plastic Retainer
- 8mm Flat Washer
- 8mm Lock Washer
- 8mm Hex Nut

- 8mm x 30mm Hex Bolt
- (2) 8mm Flat Washers
- 8mm Lock Washer
- 8mm Hex Nut

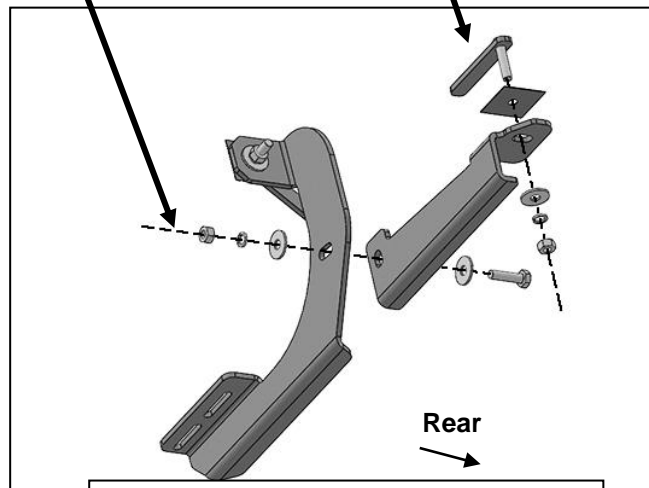

(Fig 16) Attach Passenger/Right Rear Support Bracket to bolt plate in frame

- (2) 6mm Flat Washers
- (2) 6mm Lock Washers
- (2) 6mm Hex Nuts

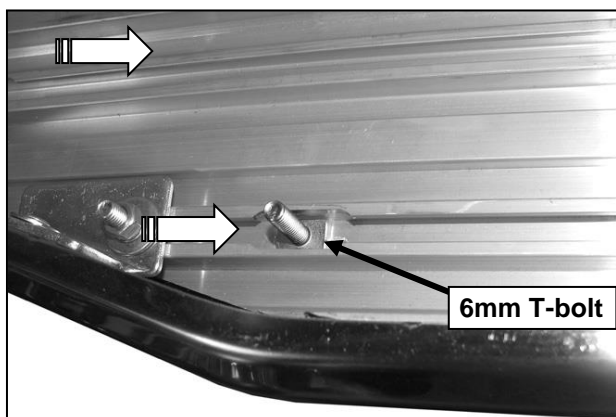

6mm T-bolt

(Fig 17) Slide (3) T-Bolts into each channel

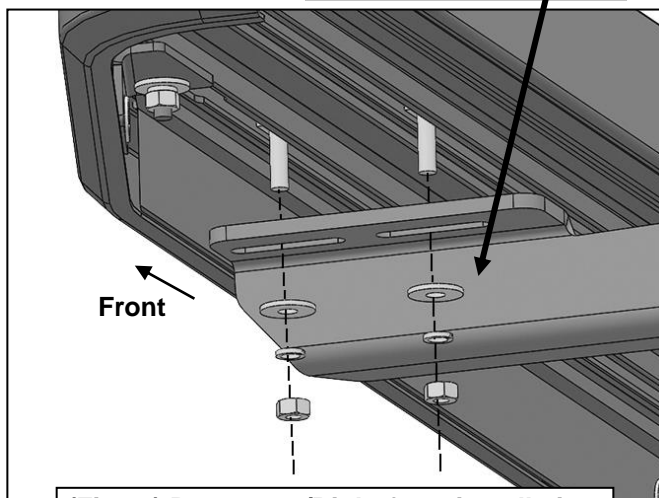

(Fig 18) Passenger/Right front installation

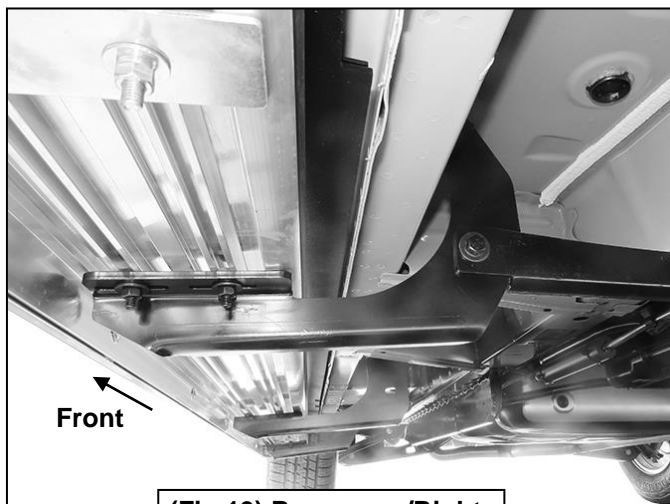

(Fig 19) Passenger/Right Running Board installed

**PRODUCT CARE**

- Periodically check the product to ensure all fasteners are tight and components are intact.
- Regular waxing is recommended to protect the finish of the product.
- **Use ONLY Non-Abrasive automotive wax.** Use of any soap, polish or wax that contains an abrasive is detrimental and can scratch the finish leading to corrosion.
- Aluminum polish may be used to polish small scratches and scuffs for **Stainless Steel finish.**
- Mild soap may be used to clean the product for both **Stainless Steel and Black finish.**

**FAQ's****1. Hardware's are not of correct size.**

*In GMC / Chevrolet truck model 2006 & up, customer needs to reuse the factory body bolts to install the bracket. If your vehicle is not GMC / Chevrolet 2006 & up, ensure that holes are not partially covered with any plastic grommet or rust? If it is, remove the plastic grommet & rust from the thread holes & re-try the installation.*

**2. Mounting Bracket are not getting Installed properly.**

*In some cases Illustration images shown in Installation manual may not be the exactly same as per actual vehicle images ,also if Driver / Passenger side mounting brackets are very identical in the design, suggest referring Parts Identification guide to avoid fitment issue.*

**3. Products are thumping / rattling after installation.**

*Ensure that all required mounting brackets / hardware's are installed & tighten correctly. Suggest using white lithium / regular grease between the metal to metal contact surfaces.*

**4. Side Bar is not aligning with vehicle / Step Pads are not aligning with vehicle doors.**

*Side bar may be interchanged or mounting brackets are not installed at the correct position in the vehicle. Refer Parts identification guide.*

**5. Missing / Excess Hardware.**

*Recheck hardware count as per the part list.*

**6. Product not installing properly.**

*Ensure make model year, cab length and bed size of your vehicle is listed in the application. All installation steps are followed correctly.*

**Check out these other TrailFX Products!!**

www.TrailFX.com

**BULL BAR****GRILLE GUARDS****BED RAILS****RUNNING BOARDS**

Keystone Automotive Operations Inc. (KAO) warrants this product to be free of defects in material and workmanship at the time of purchase by the original retail consumer. KAO disclaims any other warranties, express or implied, including the warranty of fitness for a particular purpose or an intended use. If the product is found to be defective, KAO may replace or repair the product at our option, when the product is returned prepaid, with proof of purchase. Alteration to, improper installation, or misuse of this product voids the warranty. KAO's liability is limited to repair or replacement of products found to be defective, and specifically excludes liability for any incidental or consequential loss or damage.